

SBG SOLUTION MODULAR SYSTEM.



Design Concept

Our company is specialized to create and develop well-organized storage and transportation systems within our equipment.

- We have corporate responsibility so we manufacture our products with great ecological responsibility reducing the environmental footprint in each of our factories.



SBG SECURITY

SBG IS THE PERFECT PARTNER TO MANAGE CLINICS AND HOSPITALS.

Our commitment is to present products that help to manage and organize your clinic or hospital. with our multi-module combination modules to improve product features and compatibility, easy to clean more health care, saving medical staff labor. Focusing on low carbon ecology, we choose environmentally friendly powder coatings.

Standardized storage and transport tools, In these tools it is easy for secondary contamination to occur during the transit process. The storage of all types of drugs and instruments is subject to strict warehouse management standards.

With basic storage and transfer facilities such as shelving, trays, cabinets, etc., delicatessen management facilities are deficient.

The degree of standardization of storage facilities is different. The various departments have great differences and disadvantages for unified management.

Storage and sorting efficiency needs to be improved.

Part of the structure of storage products is old, the internal structure is complicated, it is not easy to clean and disinfect. Therefore, Sostecasas Business Group presents the most innovative systems to improve the work in medical centers.

Various accessories, customized functions





The integrated solution of trolley, table, cabinet medical furniture Simpler and more direct visual management

The impression of people is 80% from the eye, and the scientific visual management is essential to storage management. Medical store visual management refers to the use of the image of an intuitive storage partition color use, improves visual perception, which is a scientific management method to improve the labor productivity and accuracy, it combined with classification box, label, become an important part of medical lean management. Job satisfaction increased by more than 20%.

○ Storage Solution (Customize number of catheter hooks as required)

- 

• Catheter shelf-E
SBGSL152E
- 

• Catheter shelf-F
SBGSL152F
- 

• Plate SBGSL152F
- 

• Catheter shelf-A
SBGSL152A
- 

• Catheter shelf-D
SBGSL152D

○ Classified Storage Box

- 

• SBGSL152E
L400×W330×H110mm
- 

• SBGSL152J
L600×400×H50mm
- 

• SBGSL152K
L600×400×H150mm
- 

• SBGSL152A
L544×400×H20mm
- 

• SBGSL152C
L600×400×H200mm

SBG Medicine Storage

- Distribution Pill Box

SBGSL254
L328 × W74 × H82mm

- Tray

SBGSL254
L600 × W400 × H200mm

- ABS Medicine Box

SBGSL154B
L600 × W400 × H100mm

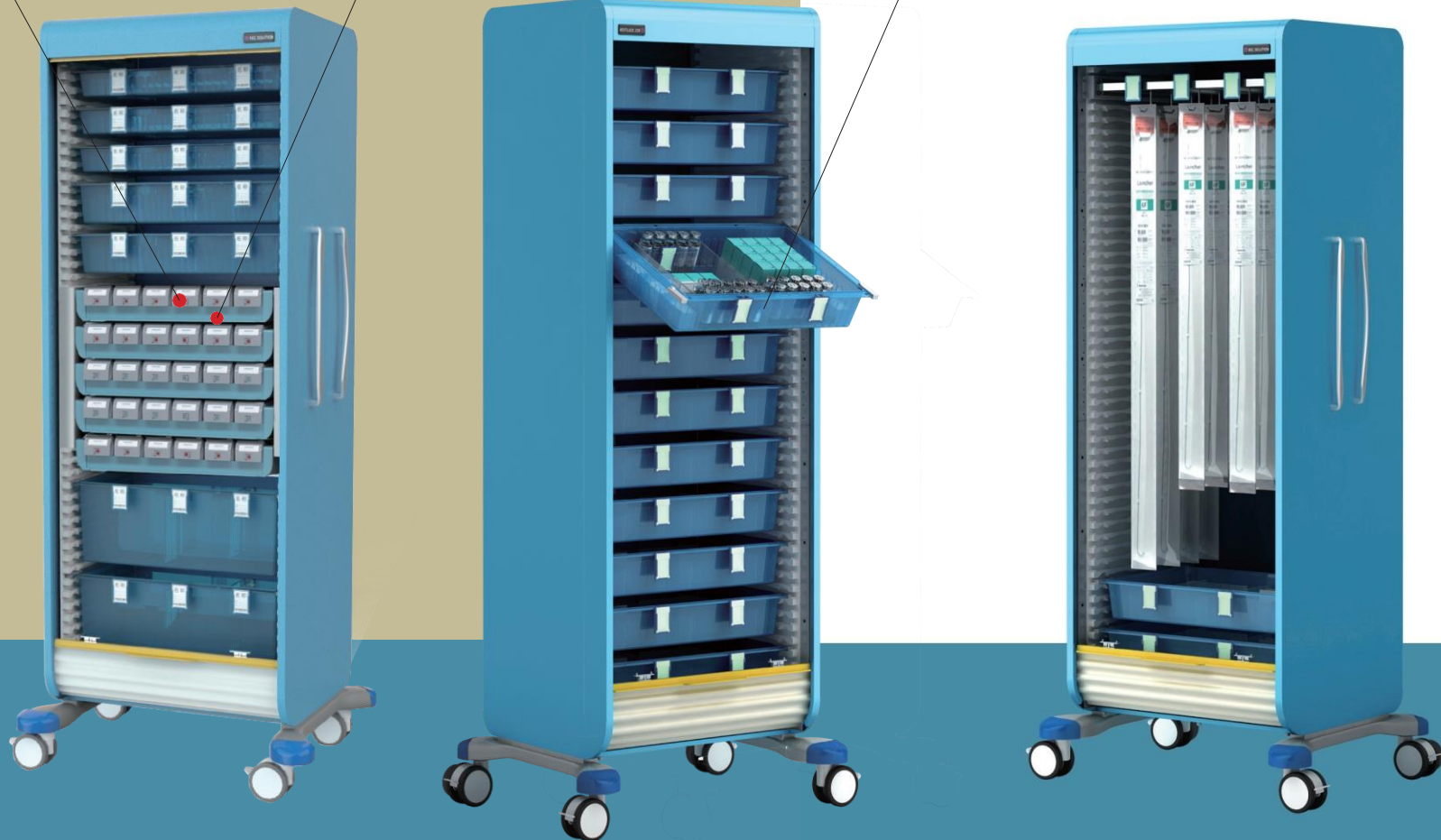

SBG ABS Medicine Basket

○ Medicine Box/Basket can be interchanged

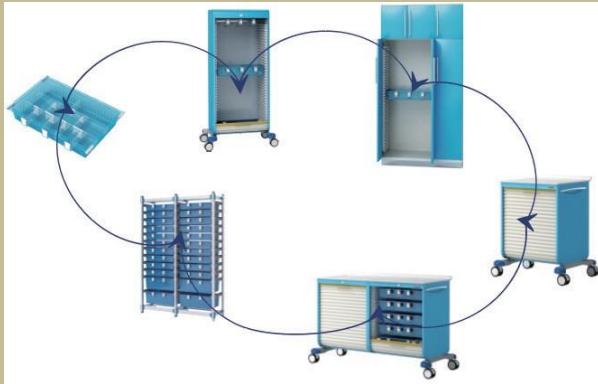

○ PC dividers adjusted freely

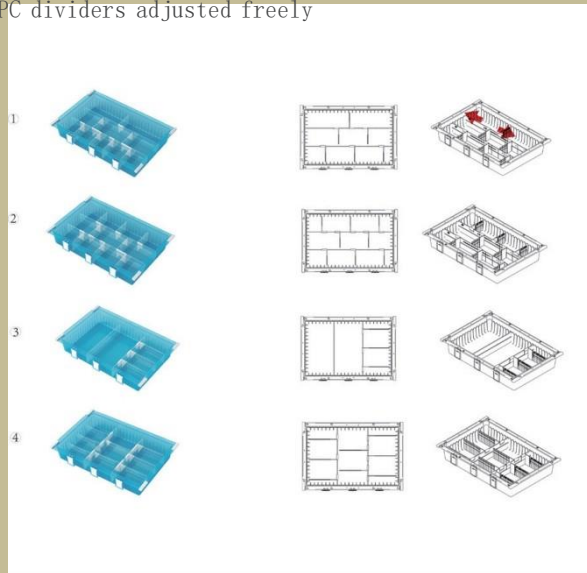

○ ABS Medicine Box/Basket

standard sizes: 600*400*50mm / 600*400*100mm / 600*400*200mm

● Transparent Basket



● Grey Box



● White Transparent Box



● Blue Transparent Box



● Grey Transparent Basket



○ Load specification:



Inclined (50mm Height box)



Inclined (100mm Height box)



Inclined (200mm Height box)



Flat (All bevoes)

○ Label Management



SBG Integrated Combination Trolley And Cabinet



Medication Trolley

SBGSL151A
L822 × W658 × H950-1475mm



Doublewide Trolley

SBGSL151B
L1487 × W658 × H950mm



Cabinet Trolley

SBGSL152A
L822 × W658 × H1635mm (Single)



Cabinet Trolley

SBGSL152B
L1487 × W658 × H1635mm (Double)



Baby Changing Unit

SBGSL153
L2152 × W658 × H950mm



Wall Cabinet

SBGSL152F
L665 × W565 × H1460mm (Single)



Wall Doublewide Cabinet

SBGSL152G
L1330 × W565 × H1460mm (Double)



Wall Top Cabinet

SBGSL152E
L655 × W565 × H500mm (Single)



Wall Sink

SBGSL154
L2055 × W585 × H777mm

SBG Integrated Combination Trolley And Cabinet



Distribution Trolley

SBGSL121

L715 × W562 × H880-1345mm



Treatment Trolley

SBGSL121

L2150 × W975 × H880-1385mm



Treatment desk

SBGSL151C

L1487 × W658 × H950-1670mm



Workstation Trolley

SBGSL152

L1000 × W658 × H950mm



Transport Trolley

SBGSL122A

L910 × W670 × H1534mm



○ Color choices

SBGSL-41	SBGSL-07	SBGSL-55
SBGSL-42	SBGSL-12	SBGSL-39
SBGSL-14	SBGSL-17	

SBG Aluminum alloy racks



Multiple Height Options

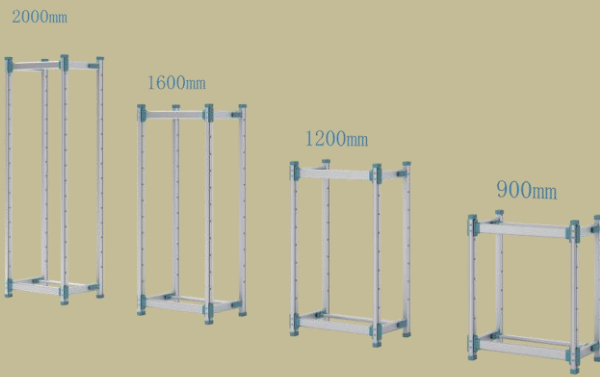

SBG Workstation Trolley



○ Multiple Height Options



Catheter Rack

SBGSL253I
L707 × W458 × H1600mm



Catheter Rack

SBGSL253K
L1360 × W458 × H2000mm



Catheter Rack

SBGSL253J
L1336 × W458 × H2000mm

SBG Workstation Trolley



Workstation Trolley

SBGSL253A

L1376×W480×H900mm



Workstation Trolley

SBGSL253B

L2030×W480×H900mm



Workstation Trolley

SBGSL253C

L2030×W975×H900mm



Medicine Trolley

SBGSL253A

L720×W480×H900mm



Medicine Trolley

SBGSL253B

L720×W480×H900mm



Medicine Trolley

SBGSL253C

L720×W480×H900mm



Medicine Trolley

SBGSL253D

L720×W480×H1200mm

SBG Rack



Rack

SBGSL253B
L707 × W458 × H2000mm



Rack

SBGSL253C
L1360 × W458 × H2000mm



Rack

SBGSL253G
L707 × W458 × H2000mm



Rack

SBGSL253D
L1360 × W458 × H2000mm



Rack

SBGSL253E
L1360 × W458 × H2000mm

SBG Racks



Rack
SBGSL253F
L1990 × W458 × H2000mm



Rack
SBGSL253H
L707 × W458 × H2000mm



Rack
SBGSL253M
L707 × W458 × H2000mm



Rack
SBGSL253N
L1360 × W458 × H2000mm



Rack
SBGSL253L
L1000 × W458 × H2000mm

SBG Storage Cabinet



Catheter Storage Cabinet

SBGSL121

L910×W670×H2000mm

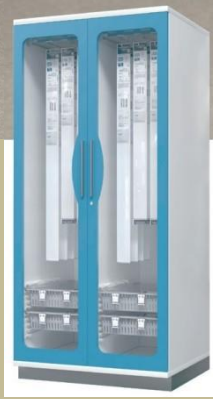

Catheter Storage Cabinet

SBGSL121A

L910×W670×H2000mm

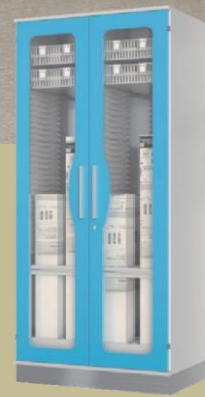

Catheter Storage Cabinet

SBGSL121B

L910×W670×H2000mm



Catheter Storage Cabinet

SBGSL 121C

L910×W670×H2000mm

SBG Storage Cabinet



Cabinet With Shelf

SBGSL121A
L910×W670×H850/2000mm



Cabinet With Shelf

SBGSL121B
L910×W670×H850/2000mm



Cabinet With Shelf

SBGSL121C
L910×W670×H850/2000mm



Cabinet With Shelf

SBGSL121A
L910×W670×H850/2000mm



Cabinet With Shelf

SBGSL121D
L665×W500×H850/2000mm



Cabinet With Shelf

SBGSL121E
L665×W500×H850/2000mm



Storage Cabinet A

SBGSL121A
L910×W670×H850/2000mm



Storage Cabinet B

SBGSL121B
L910×W670×H2000mm

SBG Storage Cabinet



Catheter Storage Cabinet

SGBSL121E

L1000 × W500 × H2000mm

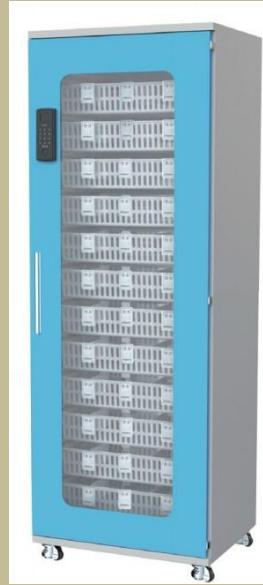

Medicine Storage Cabinet

SBGSL121D

L665 × W525 × H1850mm



Storage Cabinet C

SBGSL121C

L910 × W670 × H2000mm



Cabinet

SBGSL321

L700 × W670 × H2000mm

SBG Storage Cabinet

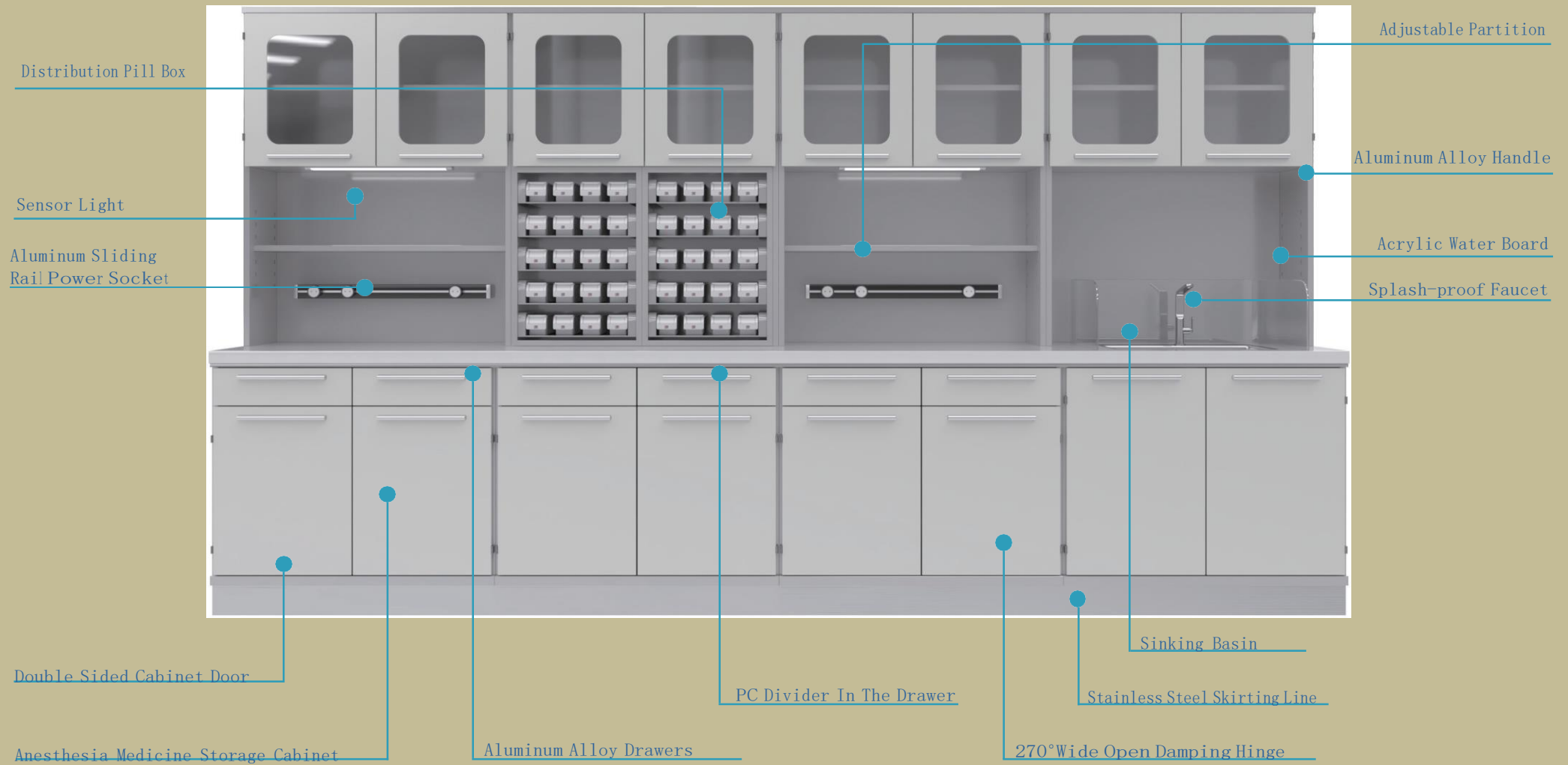

SBG Storage Cabinet



Top Cabinet

SBGSL121

L910×W390×H1150mm



Standard Cabinet

SBGSL121F

L910×W720×H850mm



Standard Cabinet

SBGSL121G

L910×W690×H850mm



Wall Sink

SBGSL121A/B

L910×W670×H850mm

L910×W670×H2000mm



Manual Waste Cabinet

SBGSL221-C

L500×W670×H850mm

Electronic Disposable Storage Solution



Product Name Electronic medicine cabinet (Master cabinet)

Model NO	SBGS-SL
Dimension	L695*W550*H1850mm
Screen	13 inch Temperature and humidity screen display
System Management	Fingerprint entry settings; IC card entry settings; Access control management combined with IC card and fingerprint; Time and date settings
Functions	(1)Ultraviolet: ① Ultraviolet time disinfection setting ② Ultraviolet time disinfection ③ Ultraviolet time switch; (2) Temperature and humidity: ① Temperature and humidity status display ② Temperature and humidity alarm setting ③ Temperature and humidity exceed standard alarm; (3)Cabinet door: ① Electronic switch door (swiping card, fingerprint) ② Automatic switch light
Voltage	220V, 50HZ
Standard Accessories	Temperature and humidity sensor; Backup key lock; 4pcs LED lights; 15W; 1pc UV disinfection lamp, 18W; Swivel casters with brake; 7pcs white transparent medicine boxes; 5 groups (35pcs) ABS medicine boxes
Optional Accessories	Electrically controlled visual glass; 50mm/100mm/200mm height blue medicine box; Stainless steel wire baskets

Product Name Electronic medicine cabinet (Affiliated cabinet)

Model NO	SBGSL
Dimension	L695*W550*H1850mm
System Management	Access control management combined with IC card and fingerprint;
Functions	(1) Ultraviolet: ① Ultraviolet time disinfection setting ② Ultraviolet time disinfection ③ Ultraviolet time switch; (2) Cabinet door: ① Electronic switch door (swiping card, fingerprint) ② Automatic switch
Voltage	220V, 50HZ
Standard Accessories	Backup key lock; 4pcs LED lights; 15W; 1pc UV disinfection lamp, 18W; Swivel casters with brake; 7pcs white transparent medicine boxes; 5 groups (35pcs) ABS medicine boxes
Optional Accessories	Electrically controlled visual glass; 50mm/100mm/200mm height blue medicine box; Stainless steel wire baskets

Electronic Disposable Storage Solution



Product Name Electronic disposable storage cabinet (Master Cabinet)

Model NO	SBGSL351A
Dimension	L695*W550*H1850mm
Screen	13 inch Temperature and humidity screen display
System Management	Fingerprint entry settings; IC card entry settings; Access control management combined with IC card and fingerprint; Time and date settings
Functions	(1)Ultraviolet: ① Ultraviolet time disinfection setting ② Ultraviolet time disinfection ③ Ultraviolet time switch; (2)Temperature and humidity: ① Temperature and humidity status display ② Temperature and humidity alarm setting ③ Temperature and humidity exceed standard alarm; (3)Cabinet door: ① Electronic switch door (swiping card, fingerprint) ② Automatic switch light
Voltage	220V, 50HZ
Standard Accessories	Temperature and humidity sensor; Backup key lock; 4pcs LED lights, 15W; 1pc UV disinfection lamp, 18W; Swivel casters with brake; 5pcs pull out partitions
Optional Accessories	Electrically controlled visual glass; 50mm/100mm/200mm height blue medicine box; Stainless steel wire baskets

Product Name Electronic disposable storage cabinet (Affiliated Cabinet)

Model NO	SBGSL351A1
Dimension	L695*W550*H1850mm
System Management	Access control management combined with IC card and fingerprint;
Functions	(1) Ultraviolet: ① Ultraviolet time disinfection setting ② Ultraviolet time disinfection ③ Ultraviolet time switch; (2)Cabinet door: ① Electronic switch door (swiping card, fingerprint) ② Automatic switch
Voltage	220V, 50HZ
Standard Accessories	Backup key lock; 4pcs LED lights, 15W; 1pc UV disinfection lamp, 18W; Swivel casters with brake; 5pcs pull out partitions
Optional Accessories	Electrically controlled visual glass; 50mm/100mm/200mm height blue medicine box; Stainless steel wire baskets

Electronic Disposable Storage Solution



Product Name Electronic catheter rack cabinet(Master cabinet)

Model NO	SBGSL351B
Dimension	L695*W550*H1850mm
Screen	13 inch Temperature and humidity screen display
System Management	Fingerprint entry settings; IC card entry settings; Access control management combined with IC card and fingerprint; Time and date settings
Functions	(1)Ultraviolet: ① Ultraviolet time disinfection setting ② Ultraviolet time disinfection ③ Ultraviolet time switch; (2) Temperature and humidity: ① Temperature and humidity status display ② Temperature and humidity alarm setting ③ Temperature and humidity exceed standard alarm; (3)Cabinet door: ① Electronic switch door (swiping card, fingerprint) ② Automatic switch light
Voltage	220V, 50HZ
Standard Accessories	Temperature and humidity sensor; Backup key lock; 4pcs LED lights, 15W; 1pc UV disinfection lamp, 18W; Swivel casters with brake; 1pc pull out catheter rack
Optional Accessories	Electrically controlled visual glass; 50mm/100mm/200mm height blue medicine box; Stainless steel wire baskets

Product Name Electronic catheter rack cabinet (Affiliated Cabinet)

Model NO	SBGSL351B1
Dimension	L695*W550*H1850mm
System Management	Access control management combined with IC card and fingerprint;
Functions	(1) Ultraviolet: ① Ultraviolet time disinfection setting ② Ultraviolet time disinfection ③ Ultraviolet time switch; (2)Cabinet door: ① Electronic switch door (swiping card, fingerprint) ② Automatic switch
Voltage	220V, 50HZ
Standard Accessories	Backup key lock; 4pcs LED lights, 15W; 1pc UV disinfection lamp, 18W; Swivel casters with brake; 1pc pull out catheter rack
Optional Accessories	Electrically controlled visual glass; 50mm/100mm/200mm height blue medicine box; Stainless steel wire baskets

Electronic Disposable Storage Solution



Product Name Electronic catheter hook cabinet (Master cabinet)

Model NO	SBGSL351C
Dimension	L695*W550*H1850mm
Screen	13 inch Temperature and humidity screen display
System Management	Fingerprint entry settings; IC card entry settings; Access control management combined with IC card and fingerprint; Time and date settings
Functions	(1)Ultraviolet: ① Ultraviolet time disinfection setting ② Ultraviolet time disinfection ③ Ultraviolet time switch; (2) Temperature and humidity: ① Temperature and humidity status display ② Temperature and humidity alarm setting ③ Temperature and humidity exceed standard alarm; (3)Cabinet door: ① Electronic switch door (swiping card, fingerprint) ② Automatic switch light
Voltage	220V, 50HZ
Standard Accessories	Temperature and humidity sensor; Backup key lock; 4pcs LED lights, 15W; 1pc UV disinfection lamp, 18W; Swivel casters with brake; Stainless steel catheter shelf, 8 hooks; 3pcs 100mm with white transparent baskets
Optional Accessories	Optional Accessories: Electrically controlled visual glass; 50mm/100mm/200mm height blue medicine box; Stainless steel wire baskets

Product Name Electronic catheter hook cabinet (Affiliated Cabinet)

Model NO	SBGSL351C1
Dimension	L695*W550*H1850mm
System Management	Access control management combined with IC card and fingerprint;
Functions	(1) Ultraviolet: ① Ultraviolet time disinfection setting ② Ultraviolet time disinfection ③ Ultraviolet time switch; (2) Cabinet door: ① Electronic switch door (swiping card, fingerprint) ② Automatic switch
Voltage	220V, 50HZ
Standard Accessories	Standard Accessories: Backup key lock; 4pcs LED lights, 15W; 1pc UV disinfection lamp, 18W; Swivel casters with brake; Stainless steel catheter shelf, 8 hooks; 3pcs 100mm with white transparent baskets
Optional Accessories	Optional Accessories: Electrically controlled visual glass; 50mm/100mm/200mm height blue medicine box; Stainless steel wire baskets

Electronic Disposable Storage Solution

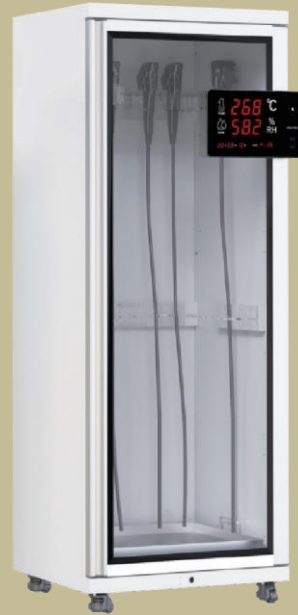

Product Name Electronic endoscopy cabinet(Master cabinet)

Model NO	SBGSL351B
Dimension	L695*W550*H1850mm
Screen	13 inch Temperature and humidity screen display
System Management	Fingerprint entry settings; IC card entry settings; Access control management combined with IC card and fingerprint; Time and date settings
Functions	(1)Ultraviolet: ① Ultraviolet time disinfection setting ② Ultraviolet time disinfection ③ Ultraviolet time switch; (2) Temperature and humidity: ① Temperature and humidity status display ② Temperature and humidity alarm setting ③ Temperature and humidity exceed standard alarm; (3)Cabinet door: ① Electronic switch door (swiping card, fingerprint) ② Automatic switch light
Voltage	220V, 50HZ
Standard Accessories	Temperature and humidity sensor; Backup key lock; 4pcs LED lights, 15W; 1pc UV disinfection lamp, 18W; Swivel casters with brake; 3 sets of stainless steel endoscopy rack; Stainless steel water basin
Optional Accessories	Optional Accessories: Electrically controlled visual glass; 50mm/100mm/200mm height blue medicine box; Stainless steel wire baskets

Product Name Electronic endoscopy cabinet(Affiliated Cabinet)

Model NO	SBGSL351B1
Dimension	L695*W550*H1850mm
System Management	Access control management combined with IC card and fingerprint;
Functions	(1) Ultraviolet: ① Ultraviolet time disinfection setting ② Ultraviolet time disinfection ③ Ultraviolet time switch; (2) Cabinet door: ① Electronic switch door (swiping card, fingerprint) ② Automatic switch
Voltage	220V, 50HZ
Standard Accessories	Backup key lock; 4pcs LED lights, 15W; 1pc UV disinfection lamp, 18W; Swivel casters with brake; 3 sets of stainless steel endoscopy rack; Stainless steel water basin
Optional Accessories	Electrically controlled visual glass; 50mm/100mm/200mm height blue medicine box; Stainless steel wire baskets

Accessories

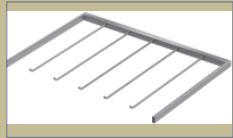

SBGSL152A
Catheter Shelf



SBGSL152B
Catheter Shelf



SBGSL152C
Catheter Holder



SBGSL152D
Catheter Holder

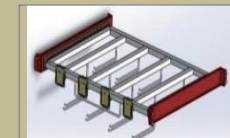

SBGSL152E-1
Catheter Holder



SBGSL152E-2
Catheter Holder



SBGSL152F
Catheter Holder



SBGSL152I
Storage Shelf



SBGSL152J
Storage Shelf



SBGSL152K
Storage Shelf



SBGSL152L
Partition board



SBGSL160
Interior Panel



SBGSL161
ABS Side rail

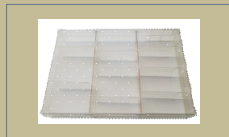

SBGSL214
Divider



SBGSL155
Lable Card



SBGSL152M
Basket

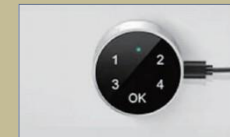

SBGSL112
Digital Lock



SBGSL154B
ABS Medicine Box (S)



SBGSL154A
ABS Medicine Box (M)



SBGSL154C
ABS Medicine Box (L)



SBGSL154G
ABS Medicine Basket



SBGSL154D
ABS Medicine Box (S)



SBGSL154E
ABS Medicine Box (M)



SBGSL154F
ABS Medicine Box (L)

Accessories

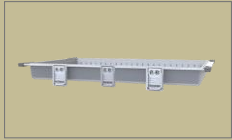

SBGSL154H
ABS Medicine Box (S)

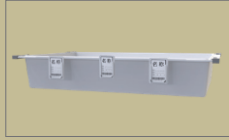

SBGSL154I
ABS Medicine Box (M)



SBGSL154J
ABS Medicine Box (L)

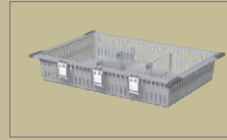

SBGSL154K
ABS Medicine Basket



SBGSL254A
Distribution Pill Box

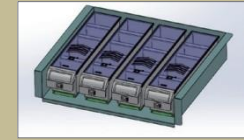

SBGSL254B
Distribution Pill Box



SBGSL251
Baby Bathtub



SBGSLP12
1
Socket



SBGSL321
Aluminum sliding rail power
socket

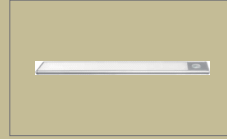

SBGSL321
Sensor light



SBGSL321
Digital Lock

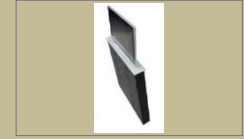

SBGSL321A
Lifting Monitor Stand
and Holder

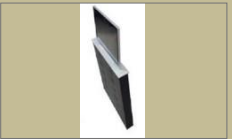

SBGSL321B
Lifting Monitor Stand

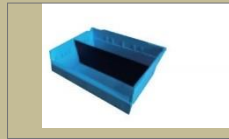

SBGSL224A
Distributions Box

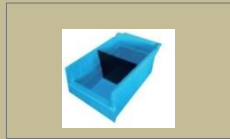

SBGSL224B
Distributions Box



SBGSL151A
Top shelf



SBGSL151B
Top shelf



SBGSL121
Top shelf



SBGSL121
Top shelf

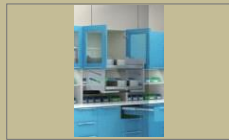

SBGSL211
Treatment table pull-
down medicine rack



SBGSL311
Thermostatic Cabinet



SBGSL351
Electronic Control Glass



SBGSL251
Baby Cushion